

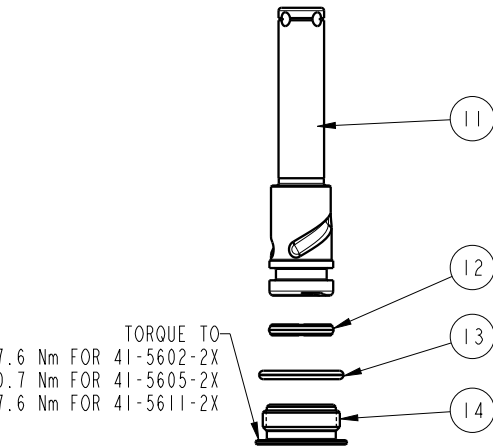

NO.	QTY.	DESCRIPTION	MODEL NO.			STANDARD SEAL KIT	FLUOROCARBON SEAL KIT
			41-5602-2X	41-5605-2X	41-5611-2X		
1	1	BUTTON HEAD CAP SCREW	21-5000-08	21-5000-09	21-5000-10	NO	NO
2	1	WIPER, ROD (FLUOROCARBON)	39-0530-04	39-0530-01	39-0530-00	YES	YES
3	1	BACK-UP RING, ROD	39-F540-00	39-F540-01	39-F540-02	YES	YES
4	1	SEAL, ROD (STANDARD)	39-0100-38	39-0100-20	39-0110-46	YES	NO
	1	SEAL, ROD (FLUOROCARBON)	39-0520-14	39-V100-20	39-V110-46	NO	YES
5	2	PLUG	43-0680-04	49-0019-04	49-0019-05	NO	NO
6	2	O-RING, MANIFOLD MOUNT	39-0500-42	39-0500-42	39-0510-76	YES	NO
	2	O-RING, MANIFOLD MOUNT (FLUOROCARBON)	39-0510-25	39-0510-25	39-V510-76	NO	YES
7	1	WASHER	21-5002-00	21-5002-00	21-5002-00	NO	NO
8	2	BUTTON HEAD CAP SCREW	21-5000-18	21-5000-18	21-5000-19	NO	NO
9	1	BALL SEAT ASSEMBLY	90-1999-88	90-1999-89	90-1999-90	YES	YES
10	2	BALL, STEEL ALLOY	23-6000-14	23-6000-11	23-6000-02	YES	YES
11	1	PLUNGER	47-5105-00	47-5109-00	47-5113-00	NO	NO
12	1	SEAL, PLUNGER (STANDARD)	39-0100-37	39-0100-18	39-0110-30	YES	NO
	1	SEAL, PLUNGER (FLUOROCARBON)	39-V100-37	39-V100-18	39-V110-30	NO	YES
13	1	O-RING, RETAINER (FLUOROCARBON)	39-V000-36	39-0510-31	N/A	YES	YES
	1	GASKET	N/A	N/A	39-T550-03	YES	YES
14	1	RETAINER	81-4000-28	81-4000-29	81-4000-30	NO	NO
N/A	N/A	SEAL KIT (STANDARD)	46-1502-04	46-1502-00	46-1502-01	INCLUDED IN KIT	
N/A	N/A	SEAL KIT (FLUOROCARBON)	46-V502-04	46-V502-00	46-V502-01		

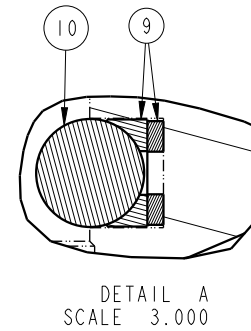
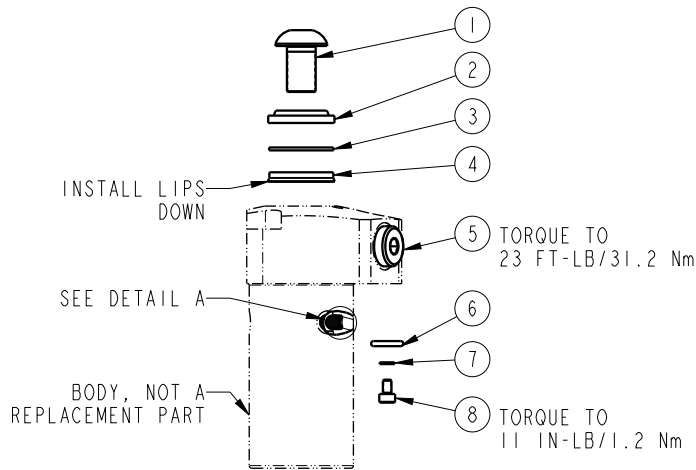

<b>PARTS LIST</b>	 <b>VEKTEK</b> VEKTEK, INC. 1334 E. SIXTH AVE. P.O. BOX 625 EMPORIA, KS. 66801 U.S.A.
	ASSEMBLIES AFFECTED
41-5602-23, 41-5605-23, 41-5611-23 41-5602-24, 41-5605-24, 41-5611-24 41-5602-26, 41-5605-26, 41-5611-26	PARTS LIST, SC, METRIC, TF, VC, DA
SIZE A MPL1542	REV B

B	5803	RELEASE	JDW	09/05/25
REV	IN ACCORDANCE WITH ECN	EFFECTIVE DATE	REVISED BY	DATE
DRW BY:	NPETERS	DRAWING STATUS: <b>Released</b>		
DATE:	8/9/21	PRODUCTION APPROVED FOR RELEASED STATUS ONLY		